

Sun 3000 Solar Simulators

210 x 210 mm Illuminated Field Systems



Abet Technologies Model 11044 A Sun 3000 210 x 210 mm Solar Simulator.

Innovative and Complete

The Abet Gen II optical design dramatically increases the percentage of photons reaching the work plane.

All electronics are packaged in the lamp house - no clutter of high power cables to deal with. Photofeedback and digital shutter timer are included.

Standard maintenance, lamp or filter replacement, does not require any tools. Locking indicator dials on all the system controls provide for a reproducible and stable setup. A built-in beam imaging accessory assists in system alignment.

Clean Cooling

Any dust or dirt particles introduced into an optical system can degrade system performance and shorten the life of critical optical components. Sun 3000 sources utilize a HEPA filtered cooling fan to extend the life of the delicate optical components.

- Class AAA Solar Simulator
- DC Xe Arc Lamp
- Gen II Optics for High Efficiency Illumination
- Digital Shutter Timer Included
- Photofeedback Included
- Long Life Lamps
- Standards Compliant

Adaptable

Abet Technologies offers a number of spectral and field size options to match your application. The Sun 3000 family standard offerings range from 50x50 mm to 400x400 mm 1 sun or more uniformly illuminated field versions for Photovoltaic and UV applications.

Beyond the standard AM 1.5 and AM 0 filters many other filters are offered to fine tune the spectral characteristics of the source for your particular application.

A low profile optical alignment system leaves the space below the system wide open for any material positioning equipment or large samples. Unit mounting options allow suspension from above leaving space below totally free if needed.

Up-pointing and horizontal output direction models also available.

Long working distances allow easy interface to vacuum boxes.

Model 11044A Specifications

IEC, ASTM and JIS Class AAA performance:

Illuminated Area.....	210 x 210 mm
Nominal working distance.....	200 mm
Irradiance range (min).....	0.7-1.1 suns
Uniformity of irradiance.....	.2%
AM 1.5G spectral match*.....	0.75-1.25
Short term stability.....	0.5%
Long term stability.....	.2%
Ozone free arc lamp.....	1000 W
Typical lamp life.....	1500 hours
HEPA filtered cooling fan included	
Built-in Photofeedback included	
Built-in electronic shutter with digital timer included	
Built-in arc lamp supply included	
110/240 VAC, 50/60 Hz, 10 A max	

*with 11082 AM filter

Ordering Information

Model 11044A includes a built-in photofeedback option to optimize temporal stability. For Sun 3000 solar simulators to be used with Abet PV IV test stations Class AAA test performance can be obtained without this option when using the irradiance reference option available with those stations.

Model 11044A does not include a filter - please choose one of the filters below to match your test needs.

Model 11044A uses a UV exposure limiting borosilicate glass lens for operator safety. For UV requiring applications, e.g. AM0 systems, order the fused silica condenser based 11044A-2 model.

The 11063 Atmospheric Absorption Filter when used with the 11044A-2 Solar Simulator causes UV output to mimic UV radiation distribution on Earth. Please ask for details.

For just UV needs, 280-400 nm, please review the Abet UV Solar Simulators specification sheets.

- 11044A** Class AAA* Solar simulator, 110x110 mm
- 11044A-2** Full spectrum Class AAA* Solar Simulator, 110x110 mm
- 11080** AM 0 filter, 3 in dia. Mounted
- 11082** AM 1.5 G filter, 70 x 70 mm
- 11057** AM 1 D filter, 3 in dia., mounted
- 11058** AM 1.5 D filter, 3 in dia., mounted
- 11059** AM 2 D filter, 3 in dia., mounted
- 11063** Atmospheric Absorption Filter
- 13024** Replacement 1000 W lamp
- 11051** Replacement HEPA filter

*With 11058, 11079 or 11080 AM filter

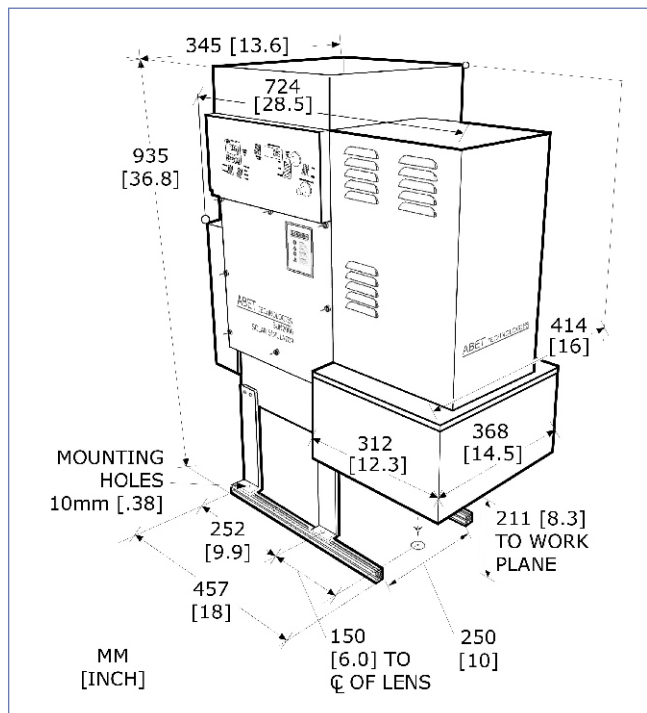

Dimensional diagram of the Abet Technologies model 11044A Class AAA Solar Simulator

Abet Technologies offers an expanding line of ASTM, IEC and JIS standards compliant products for solar cell PV-IV testing, steady state solar simulators, test stations, software, calibrated reference cells and a selection of electronic loads for low and high current cells. Visit www.abet-technologies.com or contact us at sales@abet-technologies.com.